

SESSION - 4

PI : PRODUCTION AND INDUSTRIAL ENGINEERING*Duration:* Three Hours*Maximum Marks:* 100**Read the following instructions carefully.**

1. Do not open the seal of the Question Booklet until you are asked to do so by the invigilator.
2. Take out the **Optical Response Sheet (ORS)** from this Question Booklet **without breaking the seal** and read the instructions printed on the ORS carefully. If you find that either
 - a. The Question Booklet Code printed at the right hand top corner of this page does not match with the Question Booklet Code at the right hand top corner of the **ORS** or
 - b. The Question Paper Code preceding the Registration number on the **ORS** is not **PI**, then exchange the booklet immediately with a new sealed Question Booklet.
3. On the right hand side of the **ORS**, using **ONLY a black ink ballpoint pen**, (i) darken the appropriate bubble under each digit of your registration number and (ii) write your registration number, your name and name of the examination centre and put your signature at the specified location.
4. This Question Booklet contains **16** pages including blank pages for rough work. After you are permitted to open the seal, check all pages and report discrepancies, if any, to the invigilator.
5. There are a total of 65 questions carrying 100 marks. All these questions are of objective type. Each question has only **one** correct answer. Questions must be answered on the left hand side of the **ORS** by darkening the appropriate bubble (marked A, B, C, D) using **ONLY a black ink ballpoint pen** against the question number. **For each question darken the bubble of the correct answer.** More than one answer bubbled against a question will be treated as an incorrect response.
6. Since bubbles darkened by the black ink ballpoint pen **cannot** be erased, candidates should darken the bubbles in the ORS **very carefully**.
7. Questions Q.1 – Q.25 carry 1 mark each. Questions Q.26 – Q.55 carry 2 marks each. The 2 marks questions include two pairs of common data questions and two pairs of linked answer questions. The answer to the second question of the linked answer questions depends on the answer to the first question of the pair. If the first question in the linked pair is wrongly answered or is not attempted, then the answer to the second question in the pair will not be evaluated.
8. Questions Q.56 – Q.65 belong to General Aptitude (GA) section and carry a total of 15 marks. Questions Q.56 – Q.60 carry 1 mark each, and questions Q.61 – Q.65 carry 2 marks each.
9. Questions not attempted will result in zero mark and wrong answers will result in **NEGATIVE** marks. For all 1 mark questions, $\frac{1}{3}$ mark will be deducted for each wrong answer. For all 2 marks questions, $\frac{2}{3}$ mark will be deducted for each wrong answer. However, in the case of the linked answer question pair, there will be negative marks only for wrong answer to the first question and no negative marks for wrong answer to the second question.
10. Calculator is allowed whereas charts, graph sheets or tables are **NOT** allowed in the examination hall.
11. Rough work can be done on the Question Booklet itself. Blank pages are provided at the end of the Question Booklet for rough work.
12. Before the start of the examination, write your name and registration number in the space provided below using a black ink ballpoint pen.

Name										
Registration Number	PI									

Q.1 to Q.25 carry one mark each.

Q.1 The partial differential equation $\frac{\partial u}{\partial t} + u \frac{\partial u}{\partial x} = \frac{\partial^2 u}{\partial x^2}$ is a

- (A) linear equation of order 2 (B) non-linear equation of order 1
(C) linear equation of order 1 (D) non-linear equation of order 2

Q.2 The eigenvalues of a symmetric matrix are all

- (A) complex with non-zero positive imaginary part
(B) complex with non-zero negative imaginary part
(C) real
(D) pure imaginary

Q.3 Match the **CORRECT** pairs.

Numerical Integration Scheme	Order of Fitting Polynomial
P. Simpson's 3/8 Rule	1. First
Q. Trapezoidal Rule	2. Second
R. Simpson's 1/3 Rule	3. Third

- (A) P-2, Q-1, R-3 (B) P-3, Q-2, R-1 (C) P-1, Q-2, R-3 (D) P-3, Q-1, R-2

Q.4 A rod of length L having uniform cross-sectional area A is subjected to a tensile force P as shown in the figure below. If the Young's modulus of the material varies linearly from E_1 to E_2 along the length of the rod, the normal stress developed at the section-SS is

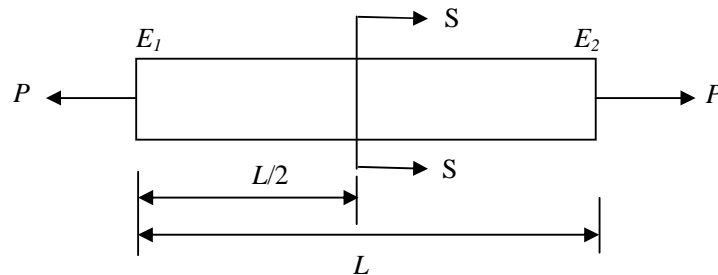

- (A) $\frac{P}{A}$ (B) $\frac{P(E_1 - E_2)}{A(E_1 + E_2)}$ (C) $\frac{PE_2}{AE_1}$ (D) $\frac{PE_1}{AE_2}$

Q.5 For steady, fully developed flow inside a straight pipe of diameter D , neglecting gravity effects, the pressure drop Δp over a length L and the wall shear stress τ_w are related by

- (A) $\tau_w = \frac{\Delta p D}{4L}$ (B) $\tau_w = \frac{\Delta p D^2}{4L^2}$ (C) $\tau_w = \frac{\Delta p D}{2L}$ (D) $\tau_w = \frac{4 \Delta p L}{D}$

Q.6 For a ductile material, toughness is a measure of

- (A) resistance to scratching (B) ability to absorb energy upto fracture
(C) ability to absorb energy till elastic limit (D) resistance to indentation

- Q.7 A cube shaped casting solidifies in 5 min. The solidification time in min for a cube of the same material, which is 8 times heavier than the original casting, will be
(A) 10 (B) 20 (C) 24 (D) 40
- Q.8 A steel bar 200 mm in diameter is turned at a feed of 0.25 mm/rev with a depth of cut of 4 mm. The rotational speed of the workpiece is 160 rpm. The material removal rate in mm³/s is
(A) 160 (B) 167.6 (C) 1600 (D) 1675.5
- Q.9 In the 3-2-1 principle of fixture design, 3 refers to the number of
(A) clamps required
(B) locators on the primary datum face
(C) degrees of freedom of the workpiece
(D) operations carried out on the primary datum face
- Q.10 In simple exponential smoothing forecasting, to give higher weightage to recent demand information, the smoothing constant must be close to
(A) -1 (B) zero (C) 0.5 (D) 1
- Q.11 A company manufactures 1000 toys every day. On an average, 10% of the toys are defective and 40% of the defective toys can be reworked into defect-free ones. The average number of defect-free toys manufactured daily is
(A) 900 (B) 920 (C) 940 (D) 960
- Q.12 Which one of the following is modeled based on adaptation capabilities of biological systems?
(A) Relational database (B) Fuzzy system
(C) Simulated annealing algorithm (D) Genetic algorithm
- Q.13 The type of control chart used to monitor the amount of dispersion in a sample is
(A) *c*-chart (B) *p*-chart (C) \bar{x} -chart (D) *R*-chart
- Q.14 The fixed cost and the variable cost of production of a product are Rs. 20000 and Rs. 50 per unit, respectively. The demand for the item is 500 units. To break even, the unit price of the items in Rs. should be
(A) 50 (B) 75 (C) 90 (D) 100
- Q.15 Therbligs refer to the
(A) basic types of fixtures used in machining.
(B) fundamental motions used in manual work.
(C) basic types of waste in manufacturing process.
(D) fundamental types of material handling systems.
- Q.16 Customers arrive at a ticket counter at a rate of 50 per hr and tickets are issued in the order of their arrival. The average time taken for issuing a ticket is 1 min. Assuming that customer arrivals form a Poisson process and service times are exponentially distributed, the average waiting time in queue in min is
(A) 3 (B) 4 (C) 5 (D) 6

- Q.17 Circular blanks of 10 mm diameter are punched from an aluminum sheet of 2 mm thickness. The shear strength of aluminum is 80 MPa. The minimum punching force required in kN is
 (A) 2.57 (B) 3.29 (C) 5.03 (D) 6.33
- Q.18 A metric thread of pitch 2 mm and thread angle 60° is inspected for its pitch diameter using 3-wire method. The diameter of the best size wire in mm is
 (A) 0.866 (B) 1.000 (C) 1.154 (D) 2.000
- Q.19 Match the **CORRECT** pairs.

Processes	Characteristics / Applications
P. Friction Welding	1. Non-consumable electrode
Q. Gas Metal Arc Welding	2. Joining of thick plates
R. Tungsten Inert Gas Welding	3. Consumable electrode wire
S. Electroslag Welding	4. Joining of cylindrical dissimilar materials

- (A) P-4, Q-3, R-1, S-2 (B) P-4, Q-2, R-3, S-1
 (C) P-2, Q-3, R-4, S-1 (D) P-2, Q-4, R-1, S-3
- Q.20 In a rolling process, the state of stress of the material undergoing deformation is
 (A) pure compression (B) pure shear
 (C) compression and shear (D) tension and shear
- Q.21 Consider one-dimensional steady state heat conduction along x -axis ($0 \leq x \leq L$), through a plane wall; with the boundary surfaces ($x=0$ and $x=L$) maintained at temperatures of 0°C and 100°C . Heat is generated uniformly throughout the wall. Choose the **CORRECT** statement.
 (A) The direction of heat transfer will be from the surface at 100°C to the surface at 0°C .
 (B) The maximum temperature inside the wall must be greater than 100°C .
 (C) The temperature distribution is linear within the wall.
 (D) The temperature distribution is symmetric about the mid-plane of the wall.
- Q.22 A cylinder contains 5 m^3 of an ideal gas at a pressure of 1 bar. This gas is compressed in a reversible isothermal process till its pressure increases to 5 bar. The work in kJ required for this process is
 (A) 804.7 (B) 953.2 (C) 981.7 (D) 1012.2
- Q.23 A planar closed kinematic chain is formed with rigid links PQ = 2.0 m, QR = 3.0 m, RS = 2.5 m and SP = 2.7 m with all revolute joints. The link to be fixed to obtain a double rocker (rocker-rocker) mechanism is
 (A) PQ (B) QR (C) RS (D) SP
- Q.24 Let X be a normal random variable with mean 1 and variance 4. The probability $P\{X < 0\}$ is
 (A) 0.5 (B) greater than zero and less than 0.5
 (C) greater than 0.5 and less than 1.0 (D) 1.0
- Q.25 Choose the **CORRECT** set of functions, which are linearly dependent.
 (A) $\sin x$, $\sin^2 x$ and $\cos^2 x$ (B) $\cos x$, $\sin x$ and $\tan x$
 (C) $\cos 2x$, $\sin^2 x$ and $\cos^2 x$ (D) $\cos 2x$, $\sin x$ and $\cos x$

Q.26 to Q.55 carry two marks each.

- Q.26 The following surface integral is to be evaluated over a sphere for the given steady velocity vector field $F = xi + yj + zk$ defined with respect to a Cartesian coordinate system having i , j and k as unit base vectors.

$$\iint_S \frac{1}{4} (\mathbf{F} \cdot \mathbf{n}) dA$$

where S is the sphere, $x^2 + y^2 + z^2 = 1$ and \mathbf{n} is the outward unit normal vector to the sphere. The value of the surface integral is

- (A) π (B) 2π (C) $3\pi/4$ (D) 4π
- Q.27 The function $f(t)$ satisfies the differential equation $\frac{d^2 f}{dt^2} + f = 0$ and the auxiliary conditions, $f(0) = 0, \frac{df}{dt}(0) = 4$. The Laplace transform of $f(t)$ is given by

- (A) $\frac{2}{s+1}$ (B) $\frac{4}{s+1}$ (C) $\frac{4}{s^2+1}$ (D) $\frac{2}{s^4+1}$

- Q.28 A flywheel connected to a punching machine has to supply energy of $400 Nm$ while running at a mean angular speed of $20 rad/s$. If the total fluctuation of speed is not to exceed $\pm 2\%$, the mass moment of inertia of the flywheel in $kg-m^2$ is

- (A) 25 (B) 50 (C) 100 (D) 125

- Q.29 A single riveted lap joint of two similar plates as shown in the figure below has the following geometrical and material details.

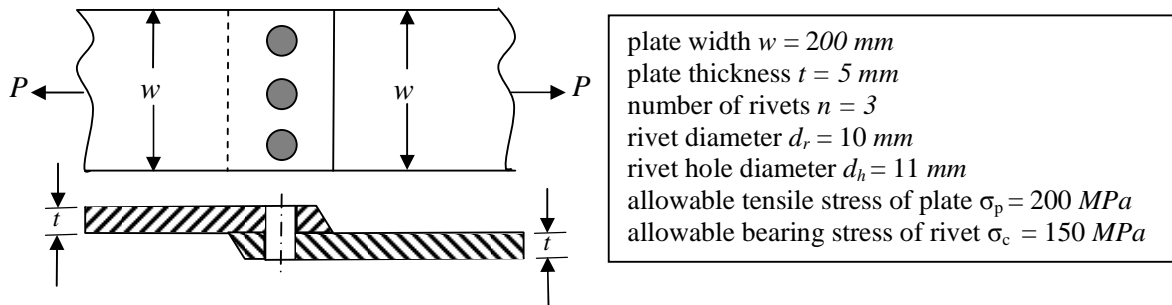

If the plates are to be designed to avoid tearing failure, the maximum permissible load P in kN is

- (A) 83 (B) 125 (C) 167 (D) 501

Q.30 Two cutting tools are being compared for a machining operation. The tool life equations are:

$$\text{Carbide tool: } VT^{1.6} = 3000$$

$$\text{HSS tool: } VT^{0.6} = 200$$

where V is the cutting speed in m/min and T is the tool life in min . The carbide tool will provide higher tool life if the cutting speed in m/min exceeds

- (A) 15.0 (B) 39.4 (C) 49.3 (D) 60.0

Q.31 In a CAD package, mirror image of a 2D point $P(5,10)$ is to be obtained about a line which passes through the origin and makes an angle of 45° counterclockwise with the X -axis. The coordinates of the transformed point will be

- (A) (7.5, 5) (B) (10, 5) (C) (7.5, -5) (D) (10, -5)

Q.32 In water jet machining, the water jet is issued through a 0.3 mm diameter orifice at a pressure of 400 MPa . The density of water is 1000 kg/m^3 . The coefficient of discharge is 1.0. Neglecting all losses during water jet formation through the orifice, the power of the water jet in kW is

- (A) 25.3 (B) 50.6 (C) 75.9 (D) 101.2

Q.33 A linear programming problem is shown below.

$$\text{Maximize } 3x + 7y$$

$$\text{Subject to } \begin{aligned} 3x + 7y &\leq 10 \\ 4x + 6y &\leq 8 \\ x, y &\geq 0 \end{aligned}$$

It has

- (A) an unbounded objective function (B) exactly one optimal solution
(C) exactly two optimal solutions (D) infinitely many optimal solutions

Q.34 Consider a two machine flow shop where jobs are first processed in Machine X and then in Machine Y, in the same sequence. The processing times of four jobs (1, 2, 3 and 4) on the machines are:

Job	Processing time (in min)	
	Machine X	Machine Y
1	6	5
2	3	4
3	7	6
4	5	4

The sequence of jobs on the machines that minimizes make span is

- (A) 2-3-1-4 (B) 1-2-3-4 (C) 2-1-3-4 (D) 3-1-4-2

- Q.35 A firm produces 120 *units* of product in every 8 *hour* shift. Four operations as given below are needed to manufacture each unit of product.

Operation	Precedence	Processing time (in <i>min</i>)
P	none	1
Q	P	2
R	P	4
S	Q, R	3

The above operations are to be assigned to workstations, such that one or more operations are performed in each workstation. Only one unit of product will be processed in each workstation at a time. The minimum number of workstations that will achieve the production target, without violating the precedence constraints, is

- (A) 1 (B) 2 (C) 3 (D) 4

- Q.36 Match the **CORRECT** pairs.

Group I	Group II
P. Man-machine chart	1. Determines standard time of jobs
Q. Learning curve	2. Finds the preferred method of doing work
R. Time study	3. Measures work improvement
S. Motion study	4. Shows idle times

- (A) P-2, Q-3, R-4, S-1 (B) P-3, Q-2, R-4, S-1
 (C) P-4, Q-1, R-3, S-2 (D) P-4, Q-3, R-1, S-2

- Q.37 A company plans to purchase a machine whose uptime needs to be atleast 95%. They have shortlisted two models of the machine with the following operational characteristics:

Machine	MTBF (<i>hr</i>)	MTTR (<i>hr</i>)
Model M	60	4
Model N	48	2

The company should buy

- (A) only Model M (B) only Model N
 (C) either Model M or N (D) neither Model M nor N

- Q.38 A manufacturer produces bars designed to be of 10 *mm* diameter with a tolerance of ± 0.1 *mm*. Historical data indicates that manufactured bars have an average diameter of 9.98 *mm* with a standard deviation of 0.15 *mm*. The process capability index is

- (A) 0.08 (B) 0.12 (C) 0.18 (D) 0.27

- Q.39 Let (P) denote the linear programming formulation of a transportation problem with m sources and n destinations. Then, the dual linear program of (P) has

- (A) $m \times n$ variables and $m \times n$ constraints (B) $m \times n$ variables and $m + n$ constraints
 (C) $m + n$ variables and $m + n$ constraints (D) $m + n$ variables and $m \times n$ constraints

- Q.40 Following data refers to an automat and a center lathe, which are being compared to machine a batch of parts in a manufacturing shop.

	Automat	Center Lathe
Machine Set-up Time in <i>min</i>	120	30
Machine Set-up Cost in <i>Rs./min</i>	800	150
Machining Time per piece in <i>min</i>	2	25
Machining Cost in <i>Rs./min</i>	500	100

Automat will be economical if the batch size exceeds

- (A) 28 (B) 32 (C) 61 (D) 75
- Q.41 Cylindrical pins of $25^{+0.020}_{+0.010}$ mm diameter are electroplated in a shop. Thickness of the plating is $30^{\pm 2.0}$ micron. Neglecting gage tolerances, the size of the GO gage in mm to inspect the plated components is
- (A) 25.042 (B) 25.052 (C) 25.074 (D) 25.084
- Q.42 During the electrochemical machining (ECM) of iron (atomic weight = 56, valency = 2) at current of 1000 A with 90% current efficiency, the material removal rate was observed to be 0.26 gm/s. If Titanium (atomic weight = 48, valency = 3) is machined by the ECM process at the current of 2000 A with 90% current efficiency, the expected material removal rate in gm/s will be
- (A) 0.11 (B) 0.23 (C) 0.30 (D) 0.52
- Q.43 Specific enthalpy and velocity of steam at inlet and exit of a steam turbine, running under steady state, are as given below:

	Specific enthalpy (kJ/kg)	Velocity (m/s)
Inlet steam condition	3250	180
Exit steam condition	2360	5

The rate of heat loss from the turbine per kg of steam flow rate is 5 kW. Neglecting changes in potential energy of steam, the power developed in kW by the steam turbine per kg of steam flow rate, is

- (A) 901.2 (B) 911.2 (C) 17072.5 (D) 17082.5
- Q.44 A simply supported beam of length L is subjected to a varying distributed load $\sin(3\pi x/L) Nm^{-1}$, where the distance x is measured from the left support. The magnitude of the vertical reaction force in N at the left support is
- (A) zero (B) $L/3\pi$ (C) L/π (D) $2L/\pi$
- Q.45 The probability that a student knows the correct answer to a multiple choice question is $\frac{2}{3}$. If the student does not know the answer, then the student guesses the answer. The probability of the guessed answer being correct is $\frac{1}{4}$. Given that the student has answered the question correctly, the conditional probability that the student knows the correct answer is
- (A) $\frac{2}{3}$ (B) $\frac{3}{4}$ (C) $\frac{5}{6}$ (D) $\frac{8}{9}$

Q.46 The solution to the differential equation $\frac{d^2u}{dx^2} - k \frac{du}{dx} = 0$ where k is a constant, subjected to the boundary conditions $u(0) = 0$ and $u(L) = U$, is

(A) $u = U \frac{x}{L}$ (B) $u = U \left(\frac{1 - e^{kx}}{1 - e^{kL}} \right)$ (C) $u = U \left(\frac{1 - e^{-kx}}{1 - e^{-kL}} \right)$ (D) $u = U \left(\frac{1 + e^{kx}}{1 + e^{kL}} \right)$

Q.47 The value of the definite integral $\int_1^e \sqrt{x} \ln(x) dx$ is

(A) $\frac{4}{9} \sqrt{e^3} + \frac{2}{9}$ (B) $\frac{2}{9} \sqrt{e^3} - \frac{4}{9}$ (C) $\frac{2}{9} \sqrt{e^3} + \frac{4}{9}$ (D) $\frac{4}{9} \sqrt{e^3} - \frac{2}{9}$

Common Data Questions

Common Data for Questions 48 and 49:

The demand for soap at a retailer is 40 kg per day. The retailer buys soap from a company in bulk at the cost of Rs. 50 per kg. The retailer incurs a cost of Rs. 200 to place an order to the company, and a holding cost of Rs. 0.1 per kg per day to store the soap. The lead time between the placing and receiving of orders is 3 days. The retailer's current ordering policy is to order 200 kg every 5 days.

Q.48 If the retailer uses an optimum order policy to minimize the total cost, the saving in Rs. in the total cost as compared to the current policy will be

(A) 10 (B) 20 (C) 40 (D) 50

Q.49 To avoid stock out situations, the retailer needs to place orders when the inventory level (in kg) drops to

(A) 40 (B) 60 (C) 80 (D) 120

Common Data for Questions 50 and 51:

A disc of 200 mm outer and 80 mm inner diameter is faced at a feed of 0.1 mm/rev with a depth of cut of 1 mm. The facing operation is undertaken at a constant cutting speed of 90 m/min in a CNC lathe. The main (tangential) cutting force is 200 N.

Q.50 Assuming approach and over-travel of the cutting tool to be zero, the machining time in min is

- (A) 2.93 (B) 5.86 (C) 6.66 (D) 13.33

Q.51 Neglecting the contribution of the feed force towards cutting power, the specific cutting energy in J/mm^3 is

- (A) 0.2 (B) 2 (C) 200 (D) 2000

Linked Answer Questions**Statement for Linked Answer Questions 52 and 53:**

In orthogonal turning of a bar of 100 mm diameter with a feed of 0.25 mm/rev, depth of cut of 4 mm and cutting velocity of 90 m/min, it is observed that the main (tangential) cutting force is perpendicular to the friction force acting at the chip-tool interface. The main (tangential) cutting force is 1500 N.

Q.52 The orthogonal rake angle of the cutting tool in degree is

- (A) zero (B) 3.58 (C) 5 (D) 7.16

Q.53 The normal force acting at the chip-tool interface in N is

- (A) 1000 (B) 1500 (C) 2000 (D) 2500

Statement for Linked Answer Questions 54 and 55:

A project consists of seven activities, whose durations are independent normal random variables, as shown in the table below. Activities are identified by their beginning node i and ending node j .

Activity (node i – node j)	Mean duration (in <i>days</i>)	Standard deviation (in <i>days</i>)
1 – 2	6	1
1 – 3	9	2
2 – 3	2	0.5
2 – 4	8	0.5
3 – 4	7	1
3 – 5	8	1
4 – 5	4	1

- Q.54 The critical path of the project, based on the mean activity duration, is
 (A) 1–2–3–4–5 (B) 1–2–3–5 (C) 1–3–5 (D) 1–3–4–5
- Q.55 Let Φ denote the cumulative distribution function of the standard normal random variable. The probability that all activities on the critical path, based on the mean activity duration, are completed in 22 *days* is
 (A) $\Phi^{-1}(0.333)$ (B) $\Phi^{-1}(0.816)$ (C) $\Phi^{-1}(1.664)$ (D) $\Phi^{-1}(2.235)$

General Aptitude (GA) Questions**Q.56 to Q.60 carry one mark each.**

- Q.56 Complete the sentence:
Universalism is to particularism as diffuseness is to _____.
- (A) specificity (B) neutrality (C) generality (D) adaptation
- Q.57 Were you a bird, you _____ in the sky.
- (A) would fly (B) shall fly (C) should fly (D) shall have flown
- Q.58 Which one of the following options is the closest in meaning to the word given below?
- Nadir**
- (A) Highest (B) Lowest (C) Medium (D) Integration
- Q.59 Choose the grammatically **INCORRECT** sentence:
- (A) He is of Asian origin.
(B) They belonged to Africa.
(C) She is an European.
(D) They migrated from India to Australia.
- Q.60 What will be the maximum sum of 44, 42, 40, ?
- (A) 502 (B) 504 (C) 506 (D) 500

Q.61 to Q.65 carry two marks each.

- Q.61 Out of all the 2-digit integers between 1 and 100, a 2-digit number has to be selected at random. What is the probability that the selected number is not divisible by 7?
- (A) 13/90 (B) 12/90 (C) 78/90 (D) 77/90
- Q.62 A tourist covers half of his journey by train at 60 km/h, half of the remainder by bus at 30 km/h and the rest by cycle at 10 km/h. The average speed of the tourist in km/h during his entire journey is
- (A) 36 (B) 30 (C) 24 (D) 18
- Q.63 Find the sum of the expression
- $$\frac{1}{\sqrt{1} + \sqrt{2}} + \frac{1}{\sqrt{2} + \sqrt{3}} + \frac{1}{\sqrt{3} + \sqrt{4}} + \dots + \frac{1}{\sqrt{80} + \sqrt{81}}$$
- (A) 7 (B) 8 (C) 9 (D) 10
- Q.64 The current erection cost of a structure is Rs. 13,200. If the labour wages per day increase by 1/5 of the current wages and the working hours decrease by 1/24 of the current period, then the new cost of erection in Rs. is
- (A) 16,500 (B) 15,180 (C) 11,000 (D) 10,120

Q.65 After several defeats in wars, Robert Bruce went in exile and wanted to commit suicide. Just before committing suicide, he came across a spider attempting tirelessly to have its net. Time and again, the spider failed but that did not deter it to refrain from making attempts. Such attempts by the spider made Bruce curious. Thus, Bruce started observing the near-impossible goal of the spider to have the net. Ultimately, the spider succeeded in having its net despite several failures. Such act of the spider encouraged Bruce not to commit suicide. And then, Bruce went back again and won many a battle, and the rest is history.

Which one of the following assertions is best supported by the above information?

- (A) Failure is the pillar of success.
- (B) Honesty is the best policy.
- (C) Life begins and ends with adventures.
- (D) No adversity justifies giving up hope.

END OF THE QUESTION PAPER